

NOTE: CW BRACKETS WILL USUALLY BE FREE ISSUED FOR INSTALLATION TO CW CONTRACTOR. ALL $\phi 4$ HOLES SHOULD BE PRE-DRILLED IN CW MULLIONS. ONLY TOP HOLE WILL BE PRE-DRILLED IN BRACKET, OTHER HOLES IN BRACKET SHOULD BE DRILLED ON SITE THROUGH HOLES IN CW MULLION - THIS WILL ENSURE PERFECT ALIGNMENT.

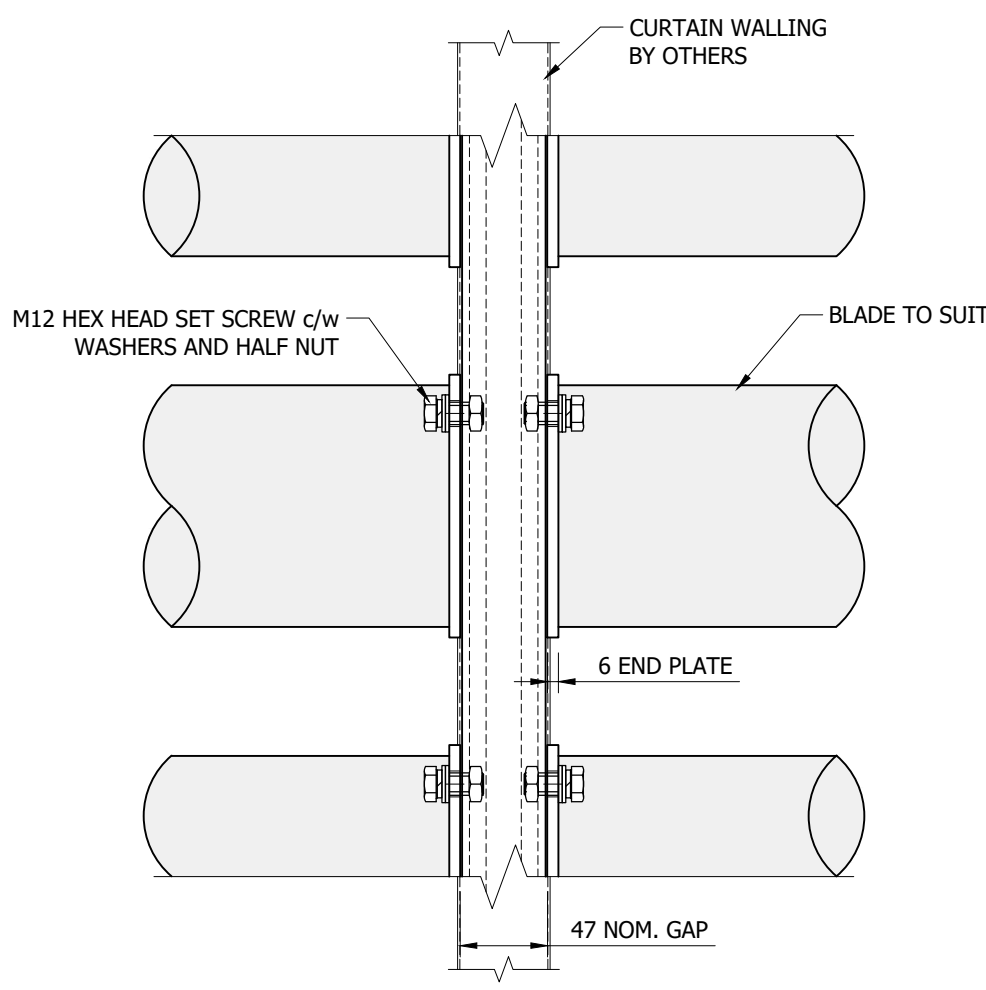

CLIMATE FACADE (TYPE 1 ARM) TO CURTAIN WALLING FIXING DETAIL

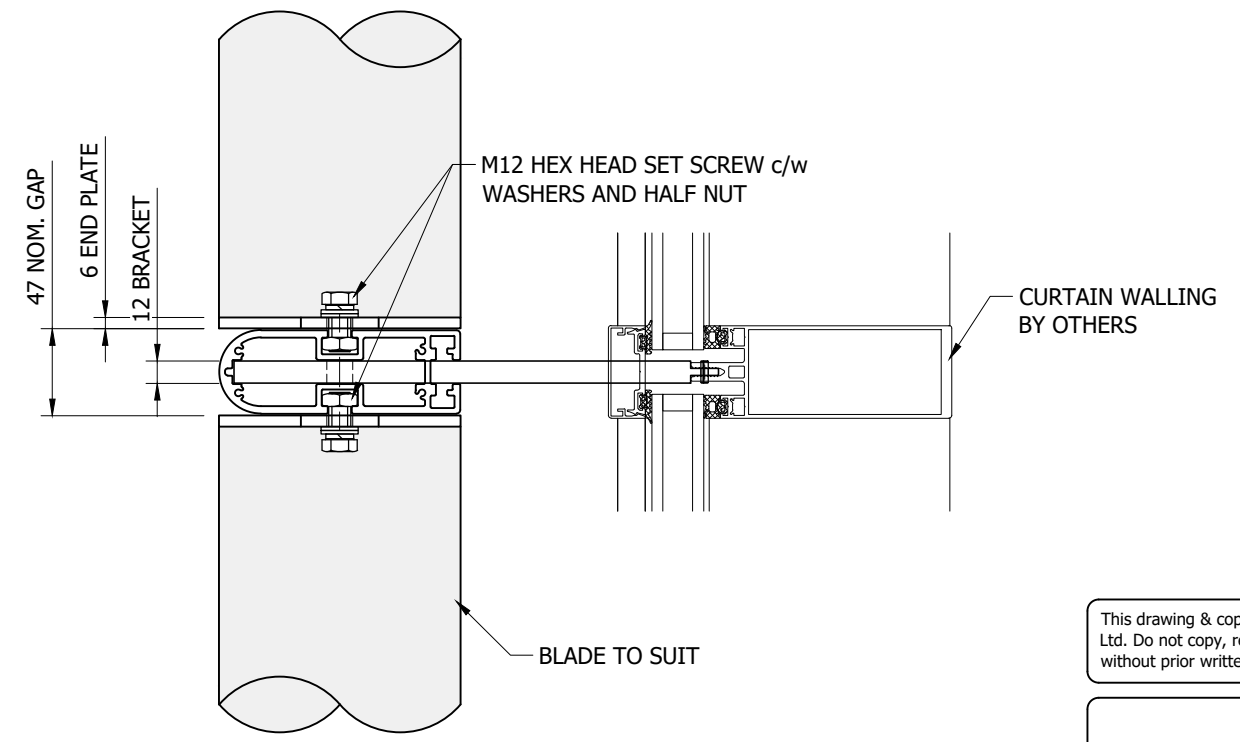
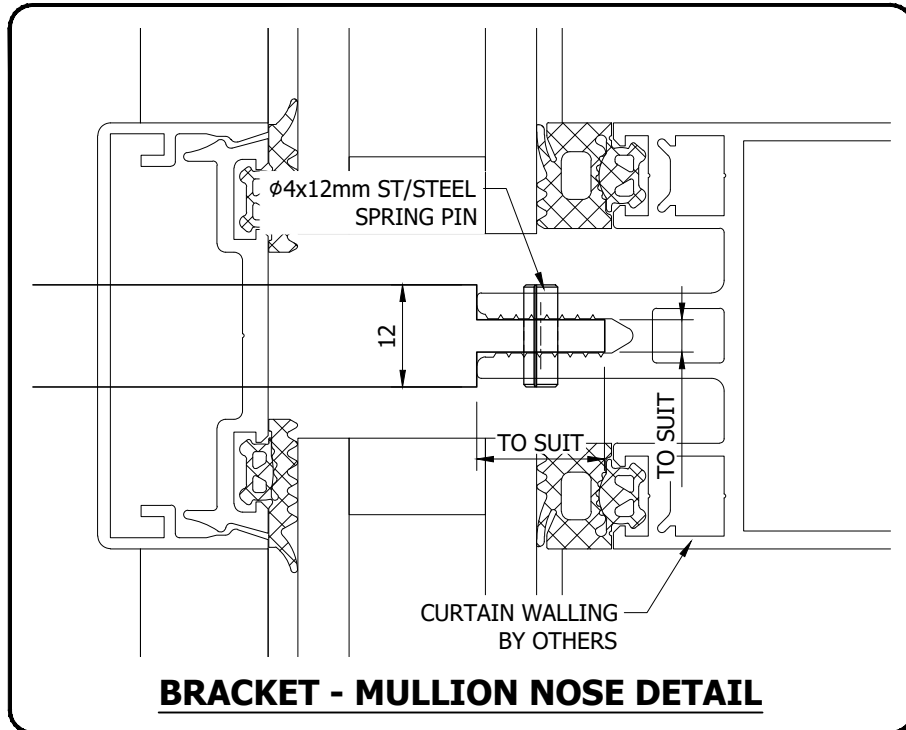
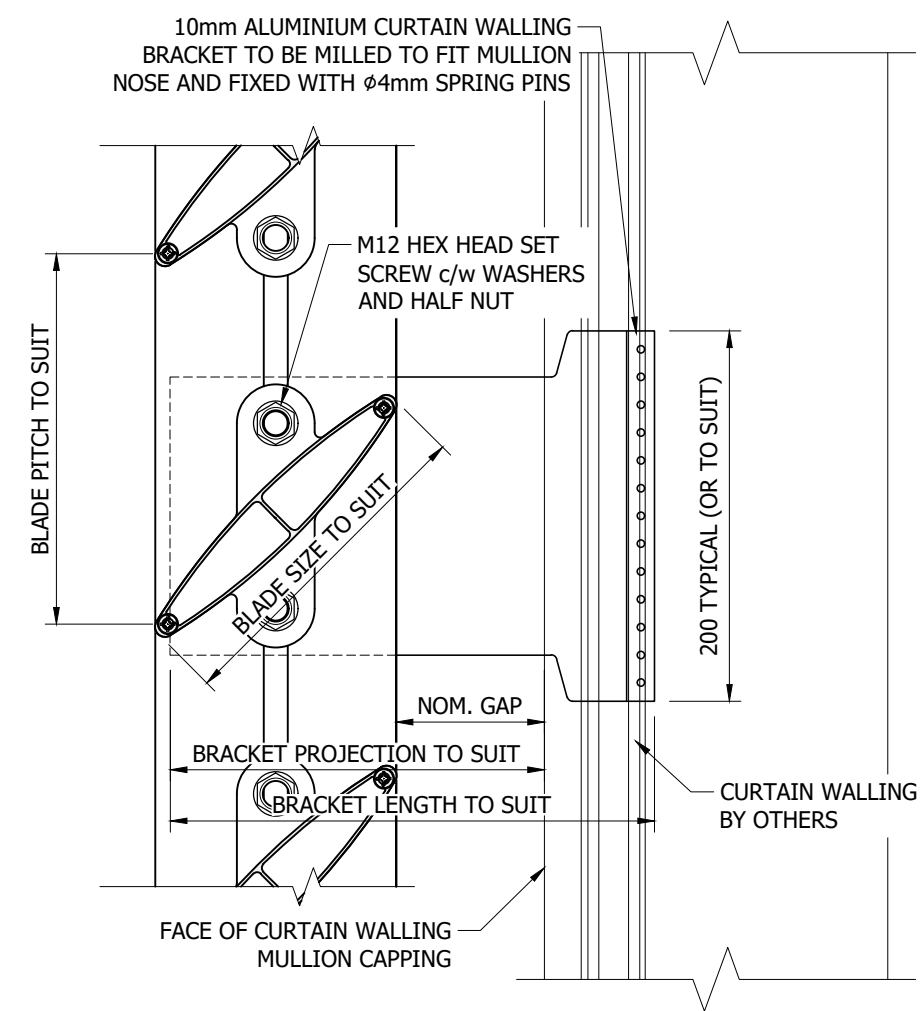

This drawing & copyright belongs to Maple Sunscreening Ltd. Do not copy, reproduce or supply any information without prior written permission.

R: Init/Date: Revision: Chk:

MAPLE

Units 11a-11d Bramhall Technology Park, Pepper Rd,
Hazel Grove, Stockport, Cheshire, SK7 5SA
Tel: 0161 456 6644
www.maplesunscreening.co.uk

Project Title:

Client:

Site Address:

Drawing Title:
**CLIMATE FACADE (TYPE 1 ARM)
FIXING DETAIL
CURTAIN WALLING**

Drawn: EMG Checked: ADJ Date: 2017

Scale: DO NOT SCALE Paper Size: A3 LANDSCAPE

Status: **INFORMATION**

Job No: Drawing No: SD-CF-FX-008 Rev: -